

IC Specifications

- IC Protocol:ISO/IEC 15693
- ISO Typical Operating Frequency:13.56MHz
- Chip:NXP SLI-X
- User Memory:896 bits
- Operating Temperature:-40°C/+85°C
- Storage Temperature:-55°C/+125°C

Antenna Design

- Aluminum Etching/30 μm
- Substrate: PET/38 μm
- Aluminum Etching/10 μm

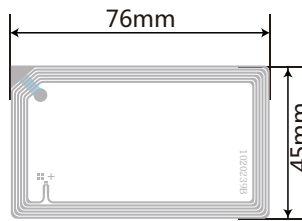

Wet Inlay Layout and Dimensions

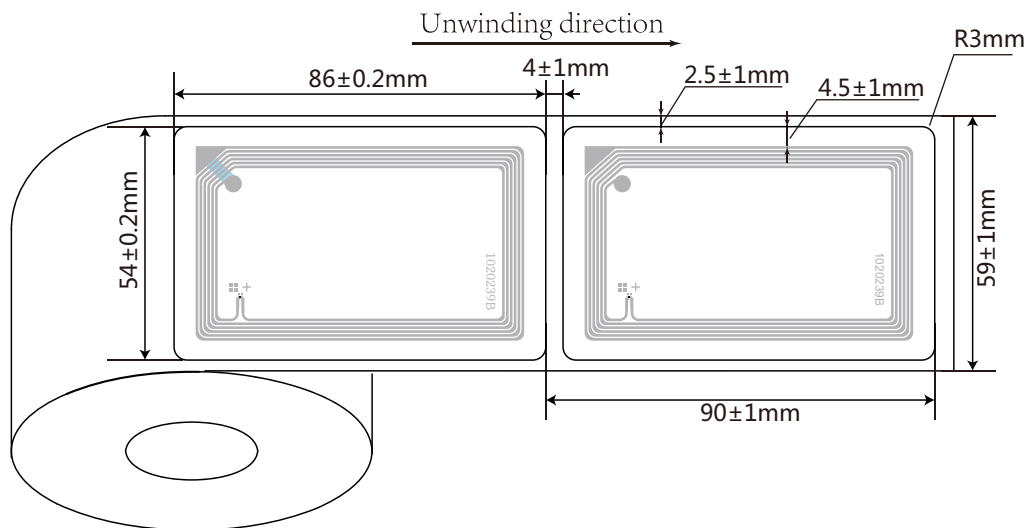

Wet Inlay Composition

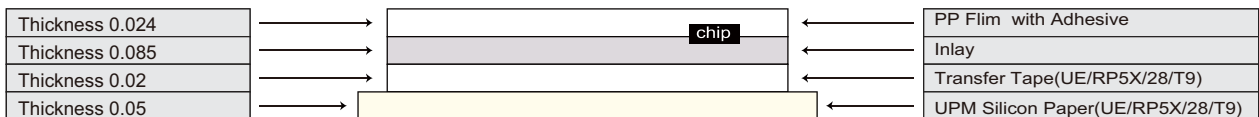

Packaging

| | |
|--|--|
| | 2,000 pcs/roll with 3 "core 1 meter leading silicon paper at the beginning and ending of roll |
| | 1 roll/inner case 300*300*88mm(TBD)/2 gaskets Φ295*3mm |
| | 3 inner cases/master ctn 320*320*295mm(TBD) |